



Caravan Annexe Measuring & Fitting Instruction Guide

Measuring the van for the annexe is as easy as 1 2 3.

First measure the length, then the width, then the height. then measure the draft strip last.

Simply follow the instructions below, enter the measurements carefully and clearly, double check and then send it to us with the Order Form and the Authorisation Form.

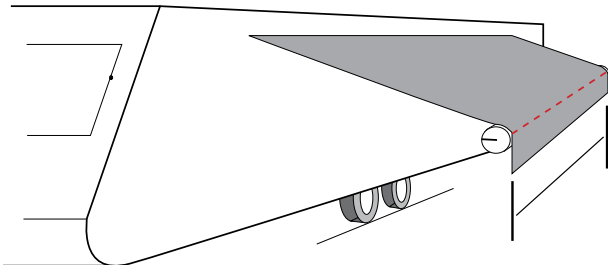

The Length

*

The length is simply measured from one edge of the awning to the other.

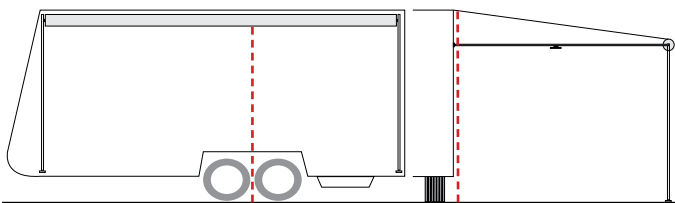

The Height

*

The height is measured from the ground to the bottom edge of the awning sail track. This measurement **MUST** be taken at the centre of the wheels. Please note: unlevel ground will not effect this measurement

(Extra measurements *1..... required for Pop-Top) *2.....

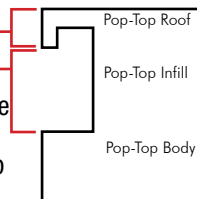

The infill measurement (1) is required from the sail track of the roll-out awning, down to the bottom of the roof lip, then down (2) to the top of the caravan body. Raise roof to measure!

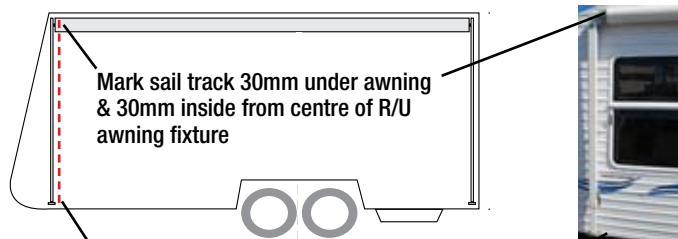

Mark sail track 30mm under awning & 30mm inside from centre of R/U awning fixture

Mark sail track 30mm above base of van & 30mm inside from centre of awning fixture

The Sail Track

*

After you have measured the draft strip, you will need to take your sail track measurement. This is the powder coated white aluminium strips that you will be installing to the side of your van. Firstly, hold your tape 30mm under the sail track of your roll-out awning on a full van, or 30mm from the top of the van body if you have a pop-top. Then take the measurement 30mm above the base of the van. Repeat this front and rear. If you have a window or an obstacle in the way, you can either stop and start the track or cut a v out of the side and bend it

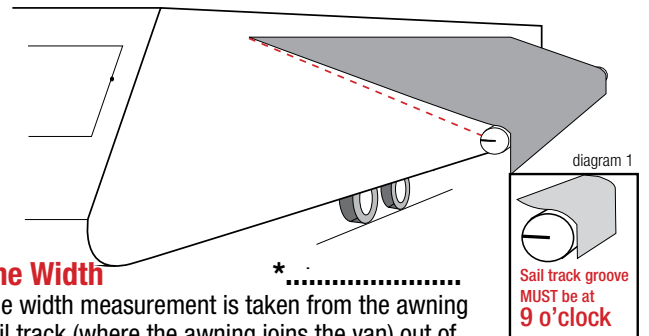

The Width

*

The width measurement is taken from the awning sail track (where the awning joins the van) out of the sail track groove in the barrel of the roll-out awning cylinder. When the awning arms are standing vertical, the position of the sail track groove should be facing back to the van. The position of this should resemble the 9 o'clock position outlined in diagram 1 above.

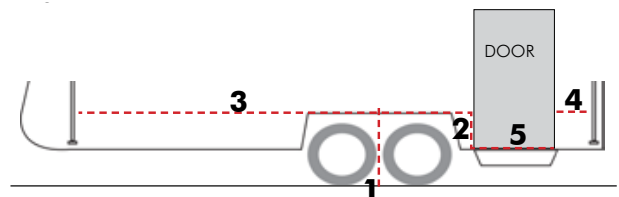

The Draft Strip

- 1 Measure from the ground to the desired height above the wheel arch and mark - *
- 2 Measure from the marked point above the wheel arch to the bottom of the door - *
- 3 Measure from door to centre of roll-out awning bracket (where awning arms attach) - *
- 4 Repeat step 3 on opposite side of door - *
- 5 Measure width of door - *
- 6 Is there a drop-down step? - Yes () No ()
- 7 Is there a window in way of sail track? - Yes () No ()
- 8 Please indicate if the door is at front of van () or at rear of van ().

Remember to **double check your measurements** before sending them on to **Australiawide Annexes...**

Visit our web site at www.australiawideannexes.com.au or call us on 1300 783 776